



JUSTIFIED & ANCIENT

TPi VISITS THE PALAIS DES SPORTS IN PARIS FOR A LESSON IN EGYPTIAN HISTORY, AND A MASTER CLASS IN DIGITAL SOUND DESIGN FROM JEAN-JACQUES DIALO...

Moroccan-born singing sensation Sofia Essaïdi, 24, is currently starring in the lead role of France's biggest stage musical of all-time: *Cléopâtre*, *La Dernière Reine d'Égypte* (*The Last Queen of Egypt*).

Spotted by *Cléopâtre*'s creator and choreographer Kamel Ouali when she participated in the third series of TF1's *Star Academy*, Essaïdi's feet have hardly touched the ground since the musical opened at the Palais des Sports in Paris on January 29.

Produced by NRJ, Jackie Lombard and Jean-Claude Camus, *Cléopâtre* boasts a cast of 44 singers, dancers and actors, 380 costumes, a crew of 52 technicians, and a 34m x 19m stage designed by Bernard Arnould with lighting by Jacques Rouveyrollis.

Currently touring France, Switzerland and Belgium and booked through until next year, this new version of the famous story of Ancient Egypt features the music and lyrics of Lionel Florence, Patrice Guirao, Pascal Obispo and David Guetta, amongst many others — even ex-Bros heartthrob Matt Goss is among the songwriting credits.

The musical namedrops don't stop there — playing Julius Caesar is Christopher Stills, the son of Véronique Sanson and Stephen Stills,

who clearly did teach his children well.

A common face amongst the crew of Kamel Ouali's productions is sound designer and FOH engineer Jean-Jacques Dialo who worked on another of Ouali's creations, *Le Roi Soleil*, and has once again favoured the InnovaSon brand.

In contrast to *Le Roi Soleil*, however, this is a very EtherSound-intensive sound design that relies on five independent but shared networks, each of them managing separate audio requirements that terminate at the FOH console.

Assisted at FOH by Arnaud Chipouka, Dialo's console choice is an InnovaSon Sy80 which receives permutations of 64 channels at any one time through the overall EtherSound network, and outputs 16 channels to the PA.

SMARTFADING

All of the music is original and on playback, with the exception of a lute cameo. The recorded music was transferred to a Tascam X48 in multitrack format to enable Dialo's 'organic' live mixing of the material, in a similar vein to how he managed playback for *Le Roi Soleil*. The Tascam is connected to a NetCIRA converter, which converts AES signals to EtherSound for the purposes of the network.

Dialo's continued favouring of the Sy80 is



Above: Sofia Essaïdi in the lead role.

Below L-R: A performer-free stage; the audio flow; Jean-Jacques Dialo and FOH assistant Arnaud Chipouka with the Sy80 console.

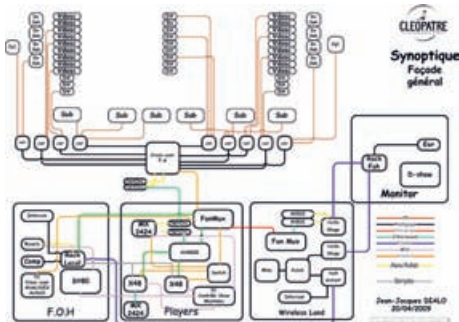

helped in no small way by his adoption of the console's Smartfade system which provide him with unlimited options for constructing the mix in the most effective manner for the show.

He said: "I really like the Sy80's modular design and find the InnovaSon approach to be more engineer-friendly than any of its competitors. You can assign any function to any fader or button so I can build my show according to the way I like to work. As far as I'm aware it's the only console on the market that allows me to do that.

"As soon as I open a fader on one of the singers, it automatically opens up a Smartfade zone at the left of the console [it could be assigned anywhere on the desk] which has four sub-faders. One is for the actual singer's microphone, another is for the understudy's mic, and the other two are for back-up mics for both in case of failure.

"Settings for every one of these were programmed into the console during rehearsals to enable instant, seamless changes in show mode."

PA COMBINATION

Dialo has also become synonymous with the combination of L-Acoustics and Meyer Sound loudspeakers. The main PA system for *Cléopâtre* consists of left/right hangs of nine V-DOSC, three dV-DOSC and four dV-Subs each side. There is a centre cluster of nine dV-DOSC cabinets, a pair of Meyer CQ-1 sidefills, eight Meyer UPJs under the stage and six additional subs on the ground.

Additionally, there are Meyer HD-1s, M'elodies and UMS1-Ps in various monitoring positions across the stage. Amplification for the L-Acoustics speakers is handled by LA48 amps while the Meyer elements are all self-powered. The system is processed via seven Lake Contour processors and two Lake Mesa EQ units.

As well as his favourite outboard kit, including Avalon VT 747s and 737s, a TC M6000 and Klark Teknik DN6000, Dialo's FOH racks accommodate all of the wares required to

PRISM
STAGE - LIGHTING - PRODUCTION

WE ARE PROUD TO HAVE SUPPLIED THE STAGE SYSTEM FOR
**THE 2009 CAPITAL FM SUMMERTIME BALL
AT THE EMIRATES STADIUM LONDON**

WE WOULD LIKE TO THANK
**STEVE LEVITT AND ALL AT PRODUCTION NORTH
AND
AEG LIVE**

WE ARE ALSO PROUD TO HAVE SUPPLIED
THE GROUND SUPPORT AND LIGHTING FOR
THE 2009 IOW FESTIVAL BIGTOP STAGE FOR THE SECOND YEAR

WE WOULD LIKE TO THANK
STEVE LEVITT AND ALL AT PRODUCTION NORTH

web site : www.prismlighting.co.uk - e-mail : mail@prismlighting.co.uk
telephone : ++44 (0)1948 820 201 - facsimile : ++44 (0) 1948 820 480

all pictures by Prism Lighting Ltd.

Below: The set and scenes from the show; radio mic world; lighting director Nicolas Gilli; JJ Dialo with the star of the show; Xavier Pion on his last trip with InnovaSon.



manage the ES-Monitor-driven network.

Designed by Alain Roy for Espace Concept, the FanMux multiplexer is a transmission system that allows several networks on a single 250m optical fibre with virtually zero latency.

“You can assign any function to any fader or button so I can build my show according to the way I like to work...”

The mix and all of the control data — including synchronisation information for the Hog III lighting console, run by Nicolas Gilli — travels up and down this cable, while an AuviTran AVM500-ES network matrix enables audio to flow in any direction.

Sébastien Rouget mixes monitors on a

Digidesign Venue D-Show desk console which, Dialo explained, was a choice enforced by Dispatch, a Digidesign distributor. “It wasn’t a console that I would have specified in preference to InnovaSon, but Dispatch did not have another one available,” he said.

“To integrate the D-Show into our network, we must convert the mix from EtherSound protocol to AES — something that would not be necessary if InnovaSon consoles were at both ends of an EtherSound network!”

The singers are fitted with Countryman E6 mics on Sennheiser headsets and wireless systems, looked after by RF technicians Frédérique ‘Fredo’ Braum and Alex Jousseau.

With both economy and ecology in mind, rechargeable batteries are in use for all radio mics and packs and are changed before each show.

Our attendance at the Palais des Sports was also the last ‘in-field’ visit for Xavier Pion in the role of InnovaSon’s sales & marketing director. He was joined at the show by his successor,

Gauthier Dalle, who was clearly relishing his new opportunity.

“With Lawo’s recent acquisition of InnovaSon, the company is in a stronger position to move forward than ever before and I’m really looking forward to the challenge of taking our business to the next step.”

Other noteworthy credits include executive producer Dinh Thien Ngo, production director Roger Abriol, technical director Philippe Graffet, projected images designer Youri Zeliviansky, video technician Charles Brun and set fabrication project manager Dominique Lebourge from Artefact. Cameleon is the lighting provider.

The *Cléopâtre* troupe is on tour until mid-December and returns to the Palais des Sports in Paris on January 14.

TPI

www.innovason.com

Photography by

Alain Guizard/Agence Angeli/CLN Spectacles,
Mark Cunningham & Kiera Leeming

RADIO MICROPHONES
IN EAR SYSTEMS
LICENSING
HIRE

hand held audio

HEARING PROTECTION
CUSTOM EARS
EARPHONES
SALES

01992 719078

www.handheldaudio.co.uk